



Tube-Line 5500

Parts & Service

Notes

Electric Solenoid valves can be manually operated by pushing a small punch into the end of spool and holding it in.

Caution Stay Away From Hoop When Engine Is Running

Inside of Control Panel , control relays are numbered CR1 to CR5 from left to right.

Relay CR1 is wired to table trigger. CR1 will activate solenoid valve to extend ram cylinder. CR2 is wired to switch at the front slider, when ram is extended to this switch CR2 will close, energizing the wrap motor valve. Ram cylinder will extend and wrap motor will turn until ram comes in contact with slider switch at rear, then CR1 and CR2 will turn off and CR3 will turn on. Wrap motor will stop and ram cylinder will retract until ram cylinder trips limit switch at front end of table. All controls will then turn off. Testing can be done by pushing trigger plate and wait until machine goes through cycle, or you can push small square button on the front of relay 1 and let machine go through cycle.

When control relays are activated a small light goes on inside the relay.

When running machine through the cycle and wrapper motor or the cylinders do not work, check flowcontrol valve to see if flow is going to both motor and cylinder.

Engine is stopped by grounding ignition, in case of ignition failure make sure that stop switch wire is not grounded to frame and engine switch is not in stop position.

Steering is controlled by switch right/left on control panel through CR4 and CR5 activating coil A or B on steering solenoid valve.

TUBE-LINE 5500

Parts Manual

Index

Item	Page #
Hoop _____	1
Hoop Wheels and Axle _____	2
Wrapper Hardware _____	3
Hoop Brace _____	4
Right hand Safety Mesh _____	5
Left Hand Safety Mesh _____	6
Drive Wheel & Hydraulic Motor _____	7
Hubs _____	8
Front Steering Assy	9
Brakes _____	10
Rear Roller _____	11
Tail _____	12
Bale Saddle _____	13
Ram _____	14
Push off _____	15
Pushoff Channel _____	16
Tongue _____	17
Mud Flap _____	18
Hydraulic Tank and Filter _____	19
Engine and Hydraulic Pump _____	20
Engine Cover and Decal Plate _____	21
Hydraulic Valve (manual) _____	22
Hydraulic Valve (electric) _____	23
Limit Switch _____	24
Control Panel _____	25
Bale Trigger and Battery Holder _____	26
Throttle _____	27
Running Lights	28
Hydraulic Schematic Diagram (manual	29
Hydraulic Schematic Diagram (electric)	30
Electric Wiring Diagram _____	31
Electric Schematic Diagram (electric)	32
Sequence Of Operation (manual) _____	33
Sequence Of Operation (electric) _____	34
Part Number _____	

Tube - Line 5500
Hoop

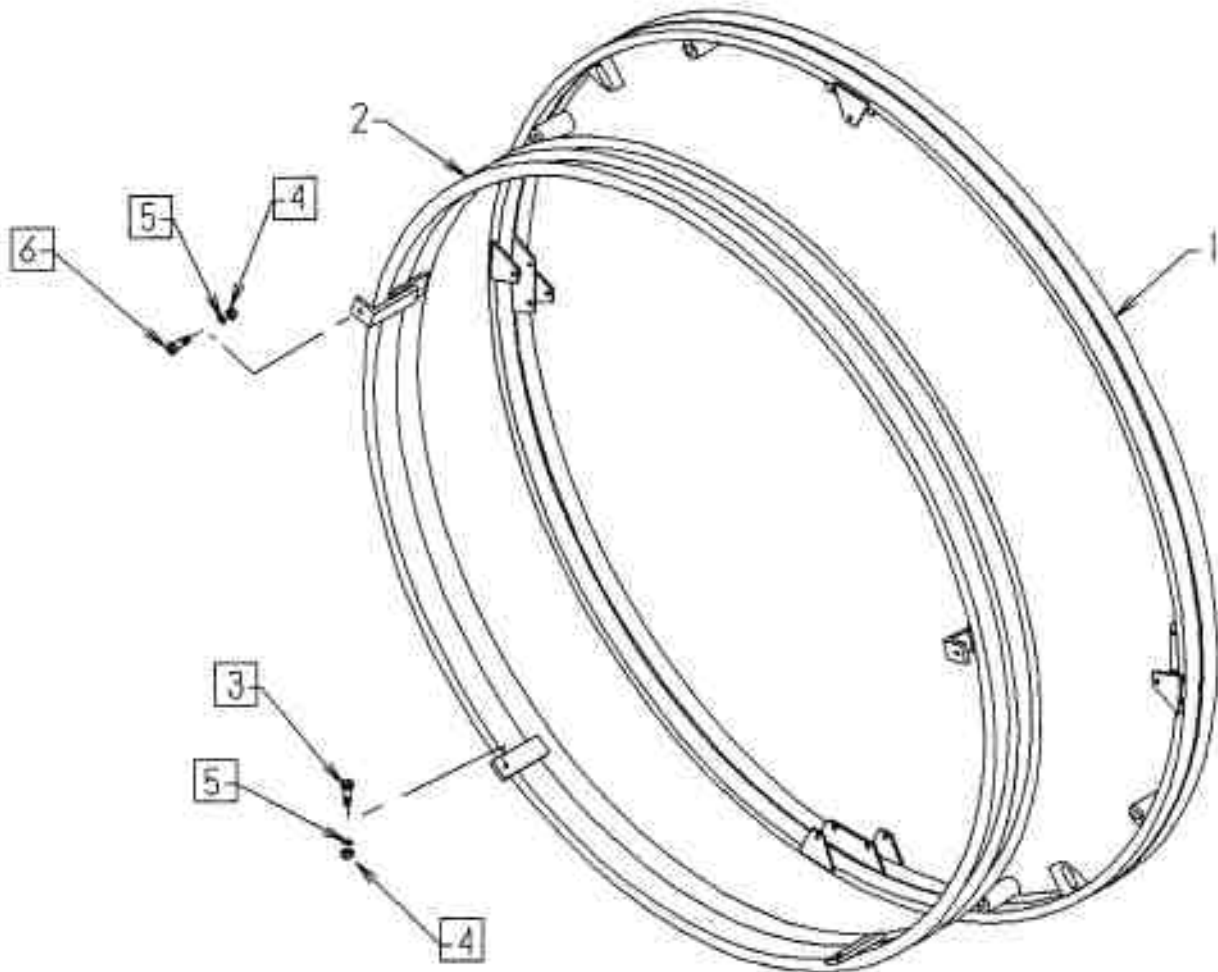

- 1 Outer Ring
- 2 Inner Ring
- 3 5/8 x 2 Bolt
- 4 5/8 Nut
- 5 5/8 Lockwasher
- 6 5/8 x 3 1/2 Bolt

Tubeline 500
Hoop Wheels

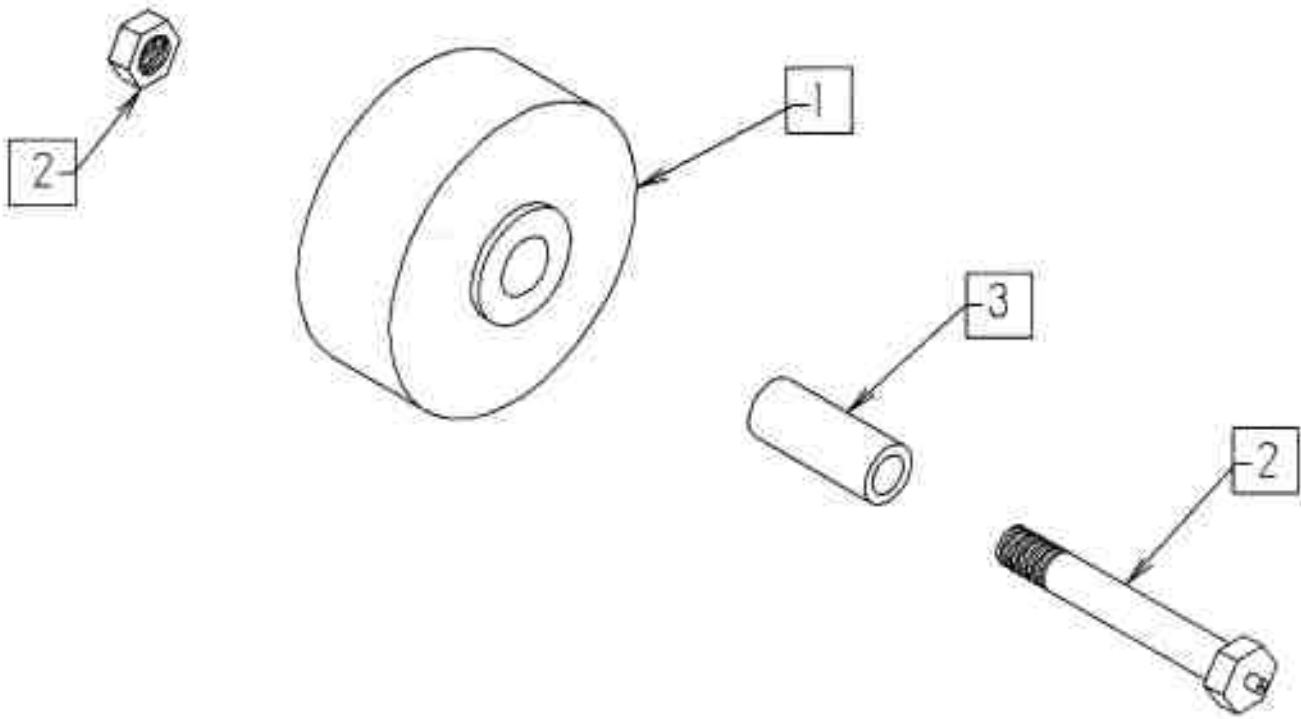

- | | |
|---|---------------------|
| 1 | 4 in Wheel |
| 2 | Axle Bolt / Locknut |
| 3 | Spanner |

Tube - Line 5500/6500
Plastic Wrap Carrier

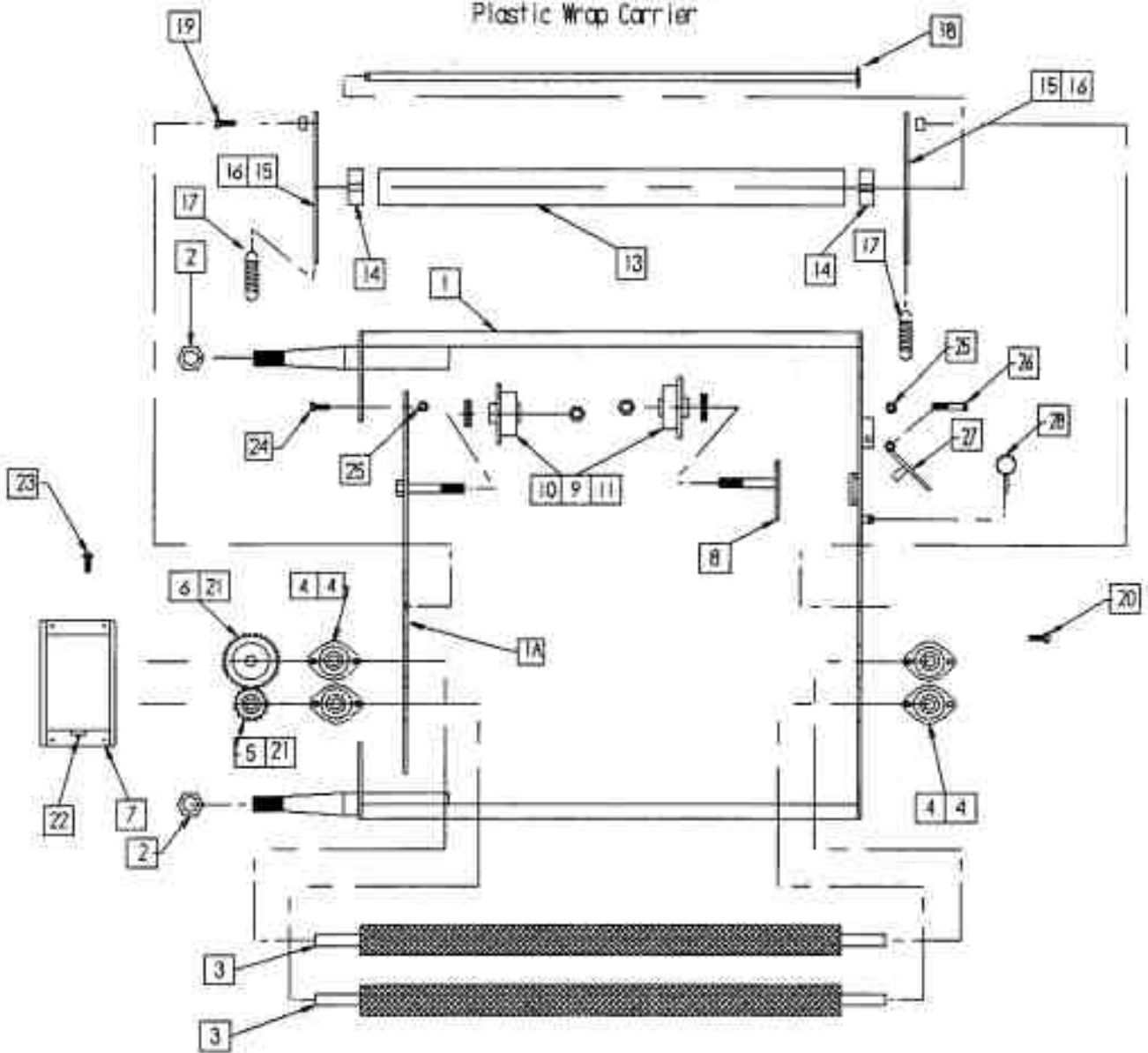

- | | | | |
|----|-----------------------|----|--------------------------|
| 1 | Main Wrap Bracket | 15 | ABS Bracket |
| 1A | Main Wrap Side Insert | 16 | Spacer |
| 2 | 1-14 UNF Casenut | 17 | Spring |
| 3 | Tensioner Roller | 18 | Axle Shaft |
| 4 | 3/4 Bearing | 19 | 1/2 x 2 Bolt |
| 5 | Small Gear | 20 | 5/16 Carriage Bolt |
| 6 | Large Gear | 21 | 3/16 Keystock |
| 7 | Gear Cover | 22 | Grease Fitting |
| 8 | Spool Holder | 23 | 10-24 x 3/4 Machine Bolt |
| 9 | Plastic Wrap Spool | 24 | 3/8 x 1 #5 Bolt |
| 10 | 5/8 Flat washer | 25 | 3/8 Locknut |
| 11 | 5/8 Nylocknut | 26 | 3/8 x 2 1/2 Bolt |
| 13 | ABS Pipe | 27 | Latch |
| 14 | HMPVC Bearing | 28 | 3/16 Linch Pin |

Tubeline 599
Hoop Brace Assy

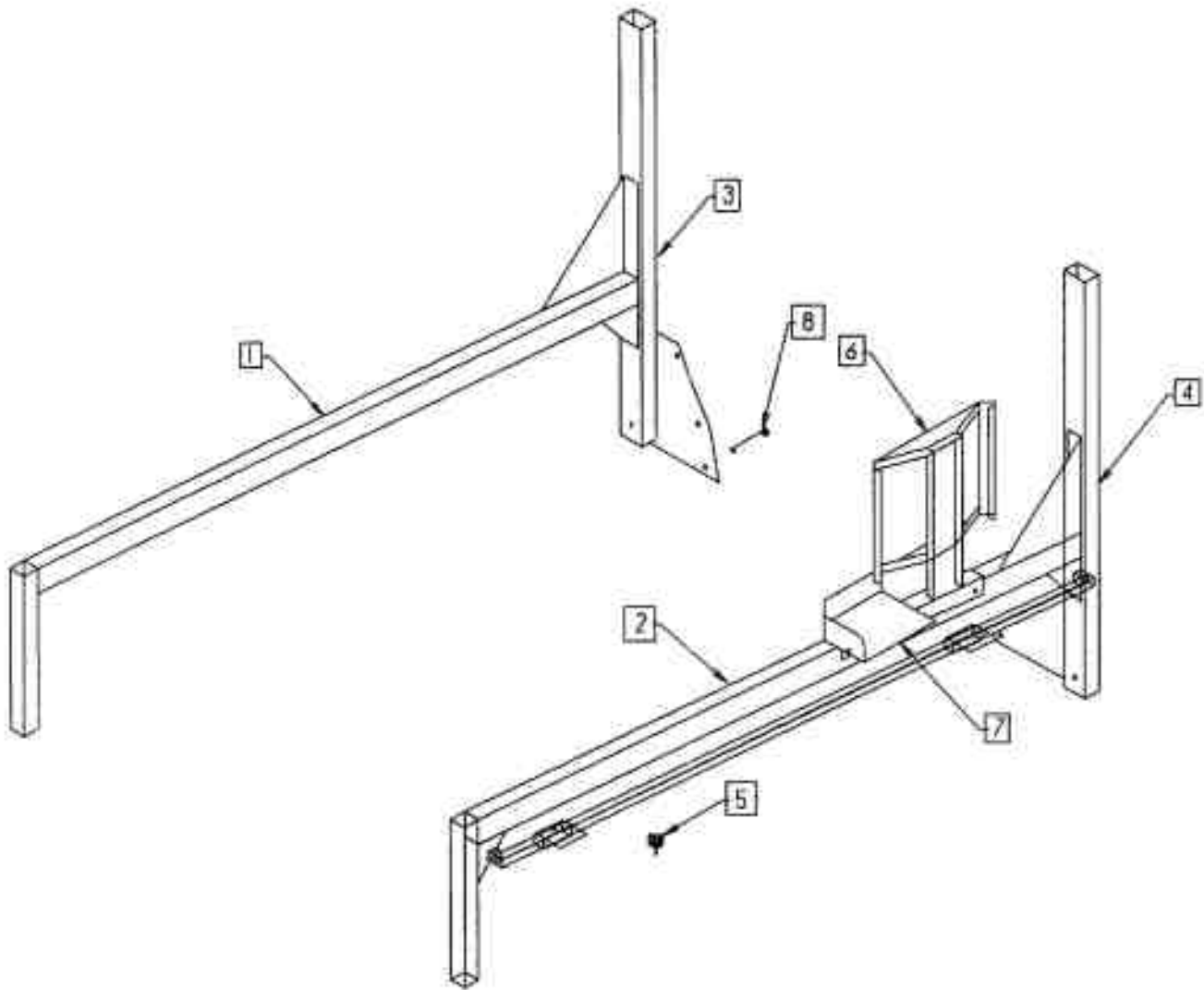

- 1 Right Hand Hoop Brace
- 2 Left Hand Hoop Brace
- 3 Right Hand Hoop Post
- 4 Left Hand Hoop Post
- 5 Switch Adjuster Screw
- 6 Automatic Control Panel Mount
- 7 Manual Control Mount
- 8 1/2 x 4 1/2 Bolt

Tubeline 5500
Right Hand Safety Guard

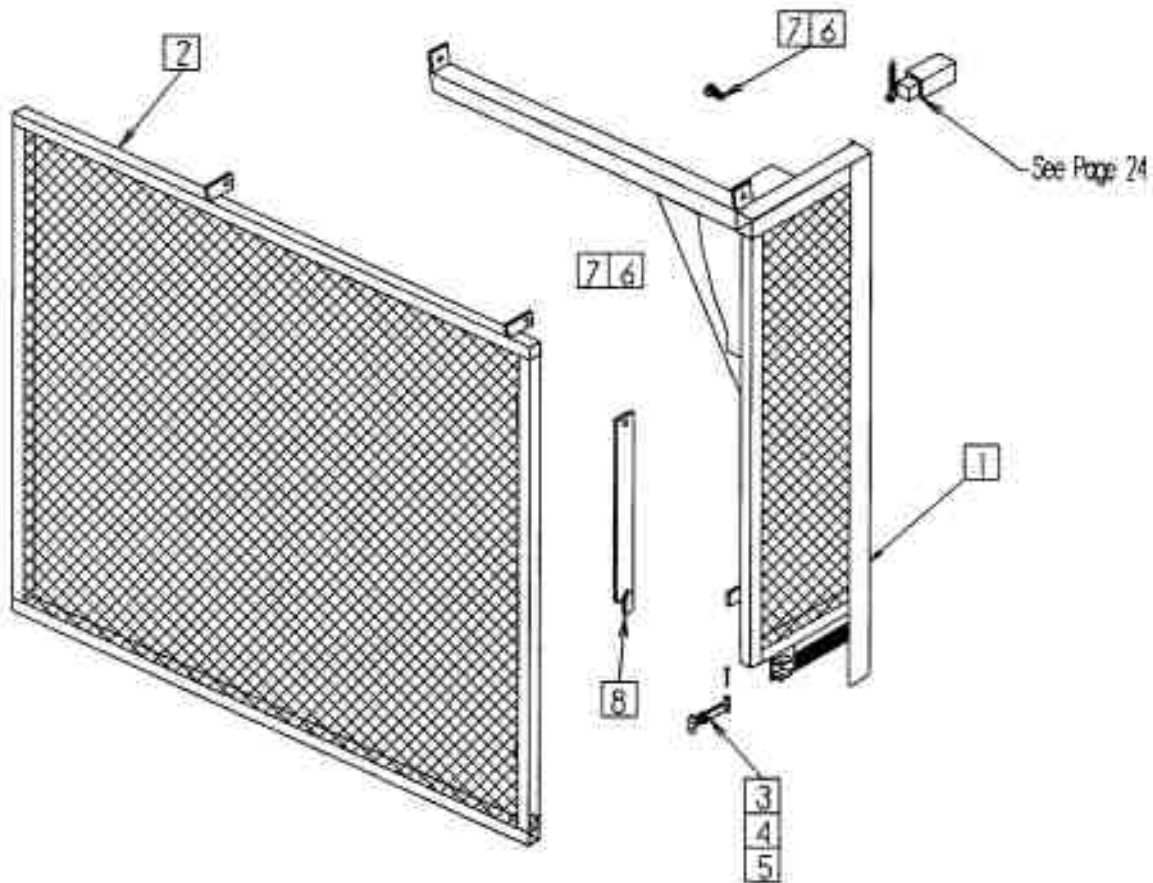

- | | |
|---|---------------------------------|
| 1 | Safety Guard Bracket Right Side |
| 2 | Safety Door Right Side |
| 3 | Rubber Latch |
| 4 | Latch Pin |
| 5 | Cotter Pin |
| 6 | 3/8 x 1 1/4 Hinge Bolt |
| 7 | 3/8 Locknut |
| 8 | Door Stay |

Tubeline 5500
Left Hand Safety Guard

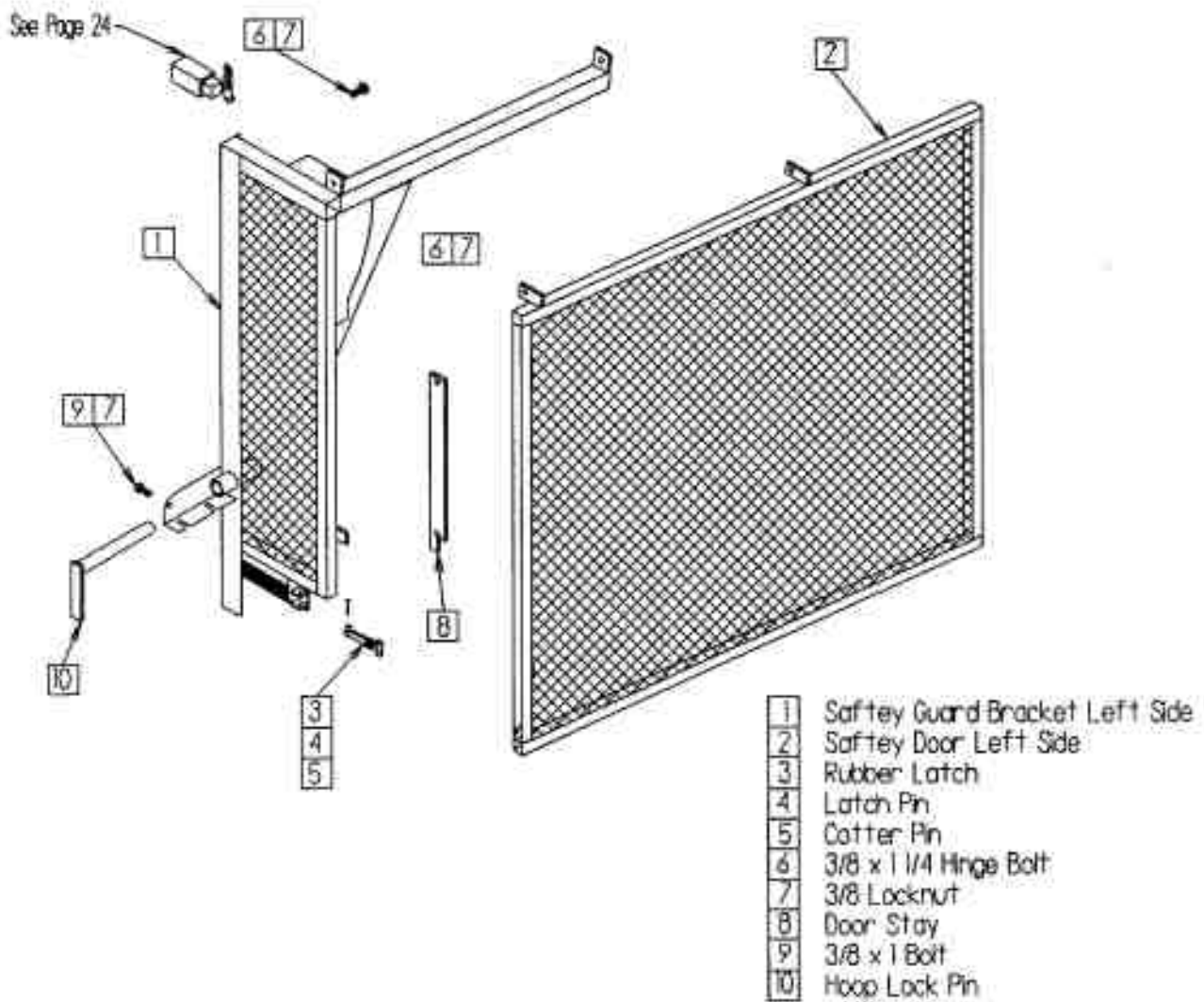

Tubeline 5500 Drive Wheel

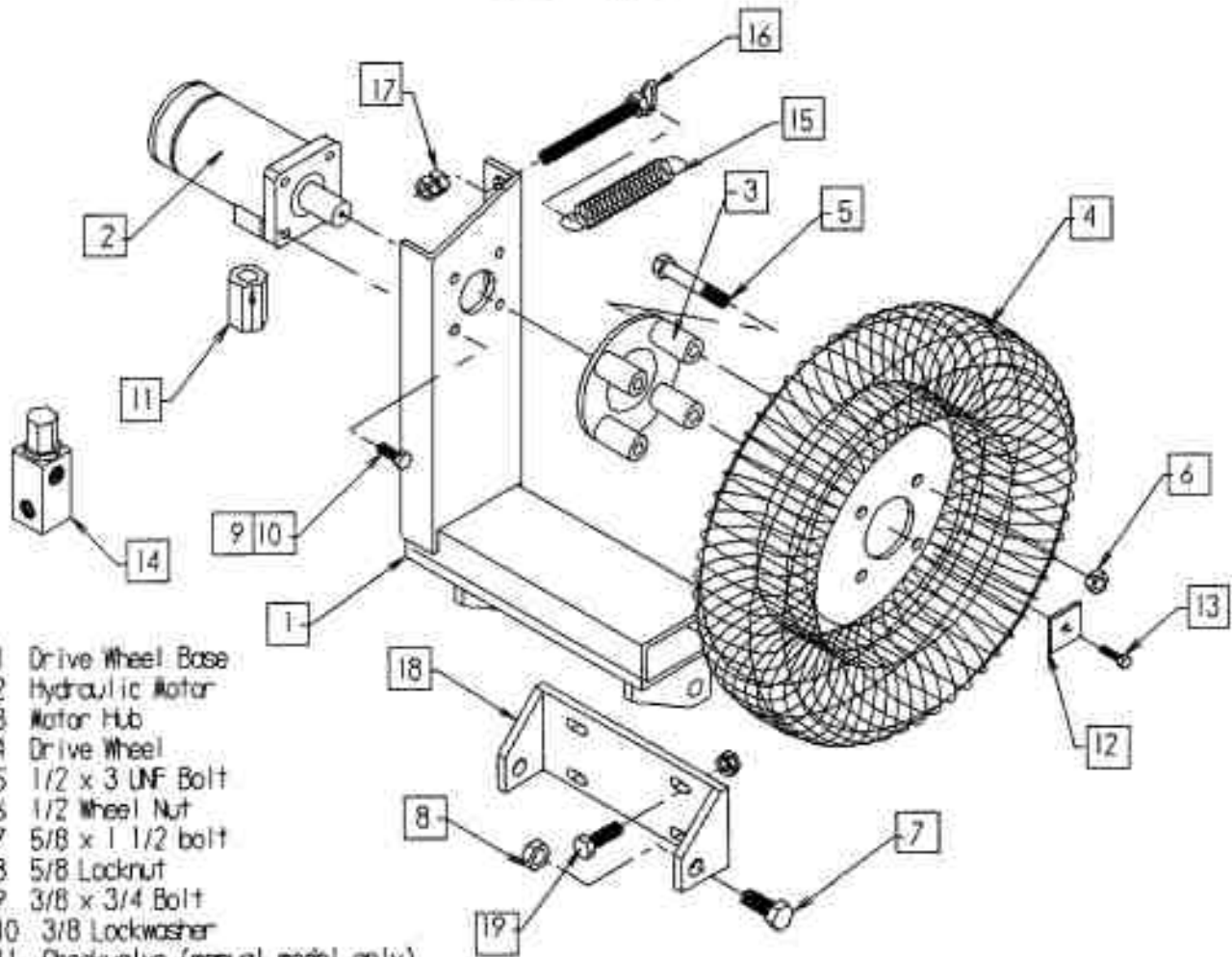

- 1 Drive Wheel Base
- 2 Hydraulic Motor
- 3 Motor Hub
- 4 Drive Wheel
- 5 1/2 x 3 UNF Bolt
- 6 1/2 Wheel Nut
- 7 5/8 x 1 1/2 bolt
- 8 5/8 Locknut
- 9 3/8 x 3/4 Bolt
- 10 3/8 Lockwasher
- 11 Checkvalve (manual model only)
- 12 Wheel Washer
- 13 1/4 x 1 Bolt c/w Lockwasher
- 14 Relief Valve (manual model only)
- 15 Wheel Tensioner Spring
- 16 Spring Tensioner Bolt
- 17 1/2 Nuts
- 18 Drive Wheel Base Bracket
- 19 3/8 x 1 1/2 bolt c/w nut, washer & lockwasher

Tube-Line 550

Axle/spindle/hub

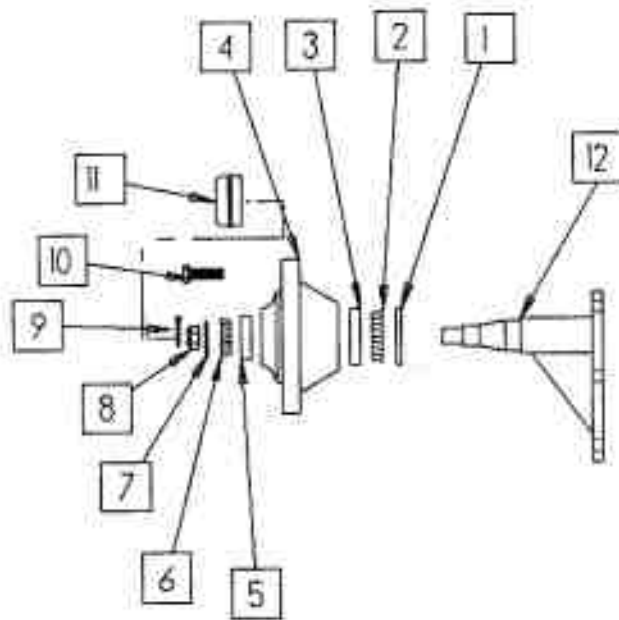

1	seal
2	inner bearing
3	inner bearing race
4	hub
5	outer bearing race
6	outer bearing
7	flat washer
8	wheel nut
9	cotter pin
10	wheel stud
11	dust cap
12	Spindle

TubeLine 5500
Front Steering Assy

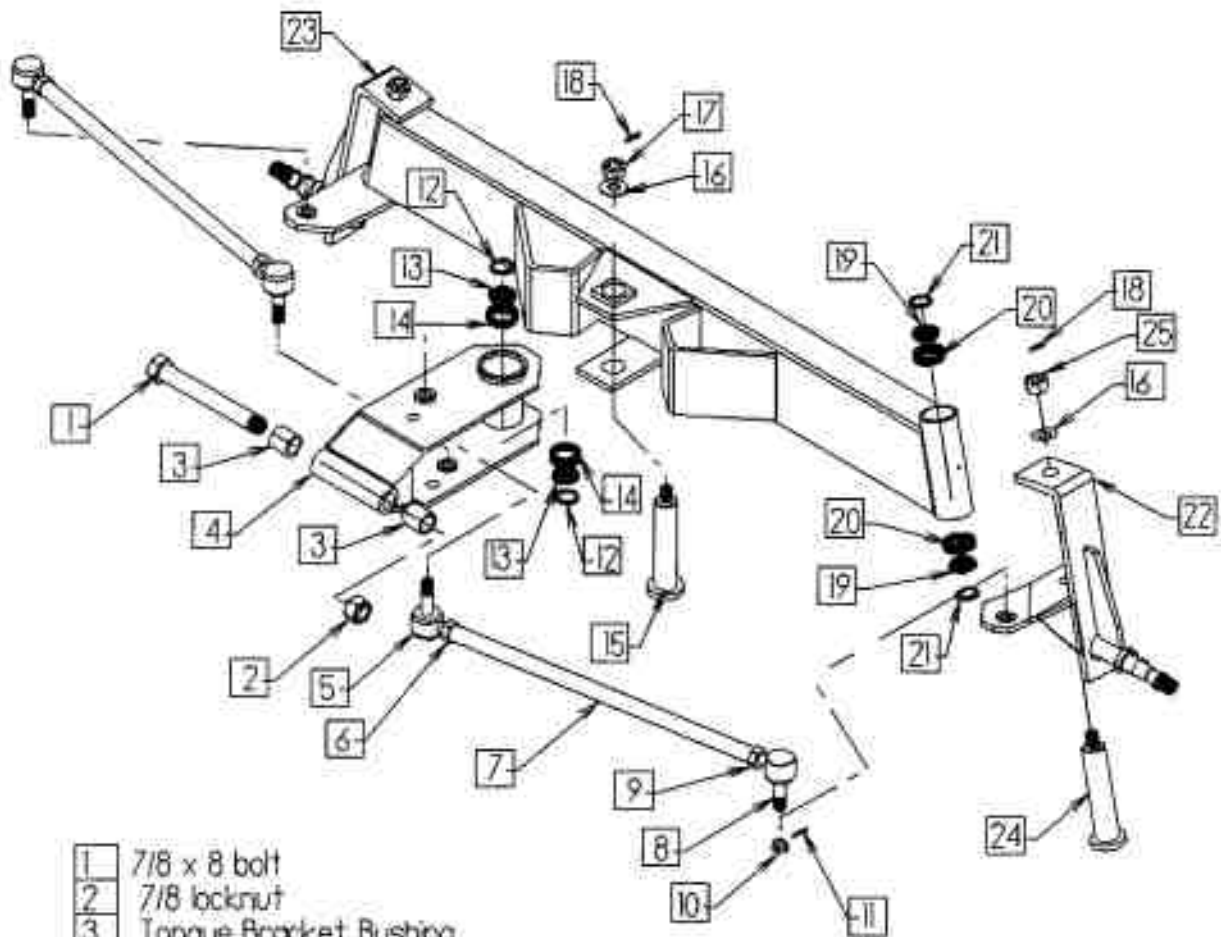

- | | |
|----|-------------------------------|
| 1 | 7/8 x 8 bolt |
| 2 | 7/8 locknut |
| 3 | Tongue Bracket Bushing |
| 4 | Tongue Bracket Assy |
| 5 | Tie Rod End - Right Thread |
| 6 | 3/4 Jam Nut (NF RH) |
| 7 | Tie Rod |
| 8 | Tie Rod End - Left Thread |
| 9 | 3/4 Jam Nut (NF LH) |
| 10 | 9/16 NF Slotted Hex Nut |
| 11 | 1/8 x 1 Cotter Pin |
| 12 | Tongue Bracket Seal |
| 13 | Tongue Bracket Timkin Bearing |
| 14 | Tongue Bracket Timkin Cup |
| 15 | Tongue Bracket Pin |
| 16 | 13/16 Flat Washer |
| 17 | Tongue Bracket Nut |
| 18 | 3/16 x 2 Cotter Pin |
| 19 | Spindle Bearing Timkin Cone |
| 20 | Spindle Bearing Timkin Cup |
| 21 | Spindle Bearing Seal |
| 22 | Left Side Spindle Assy |
| 23 | Right Side Spindle Assy |
| 24 | Spindle Pin |

Tube-Line 5500
Brakes

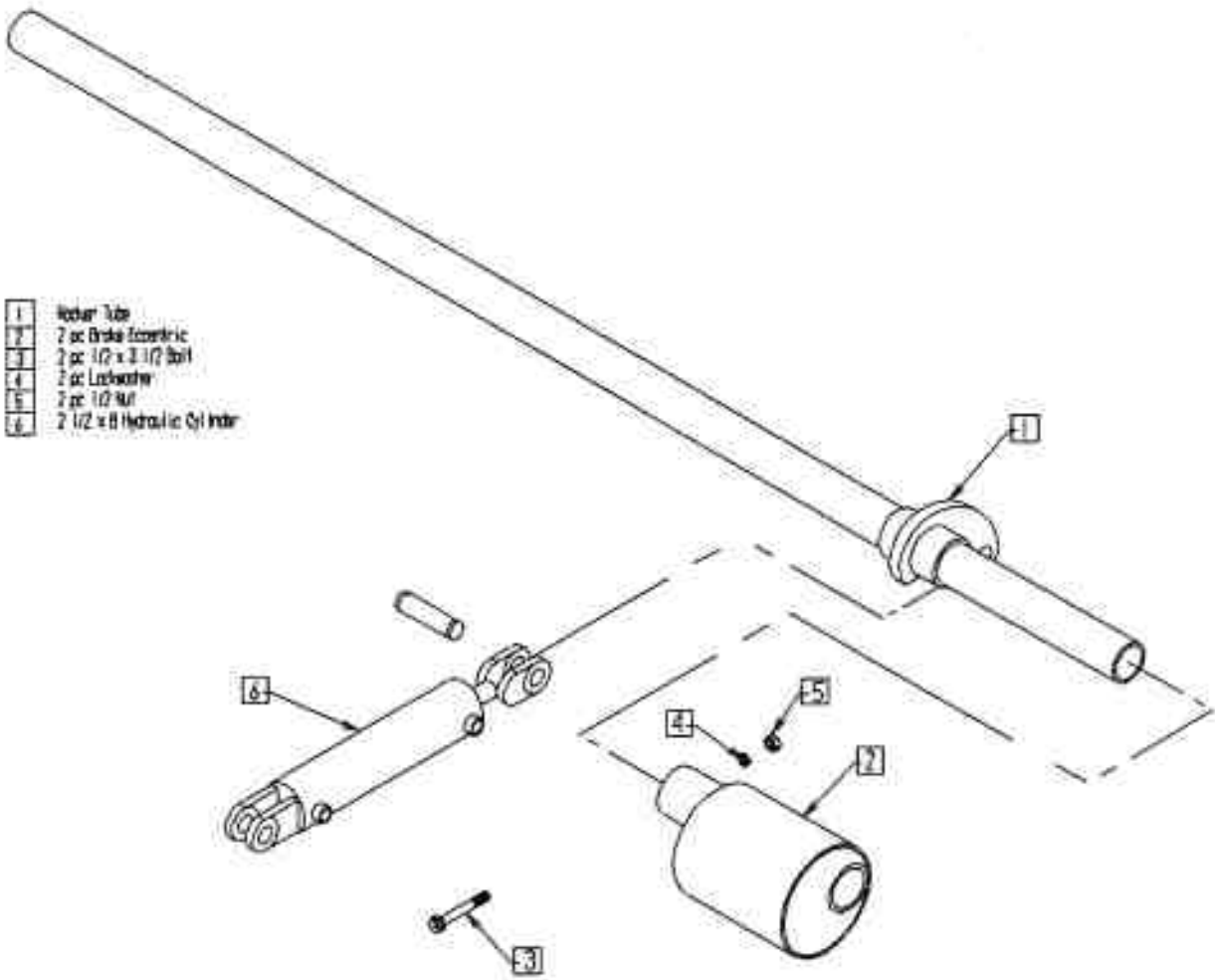

Tube-Line 9800
Rear Roller

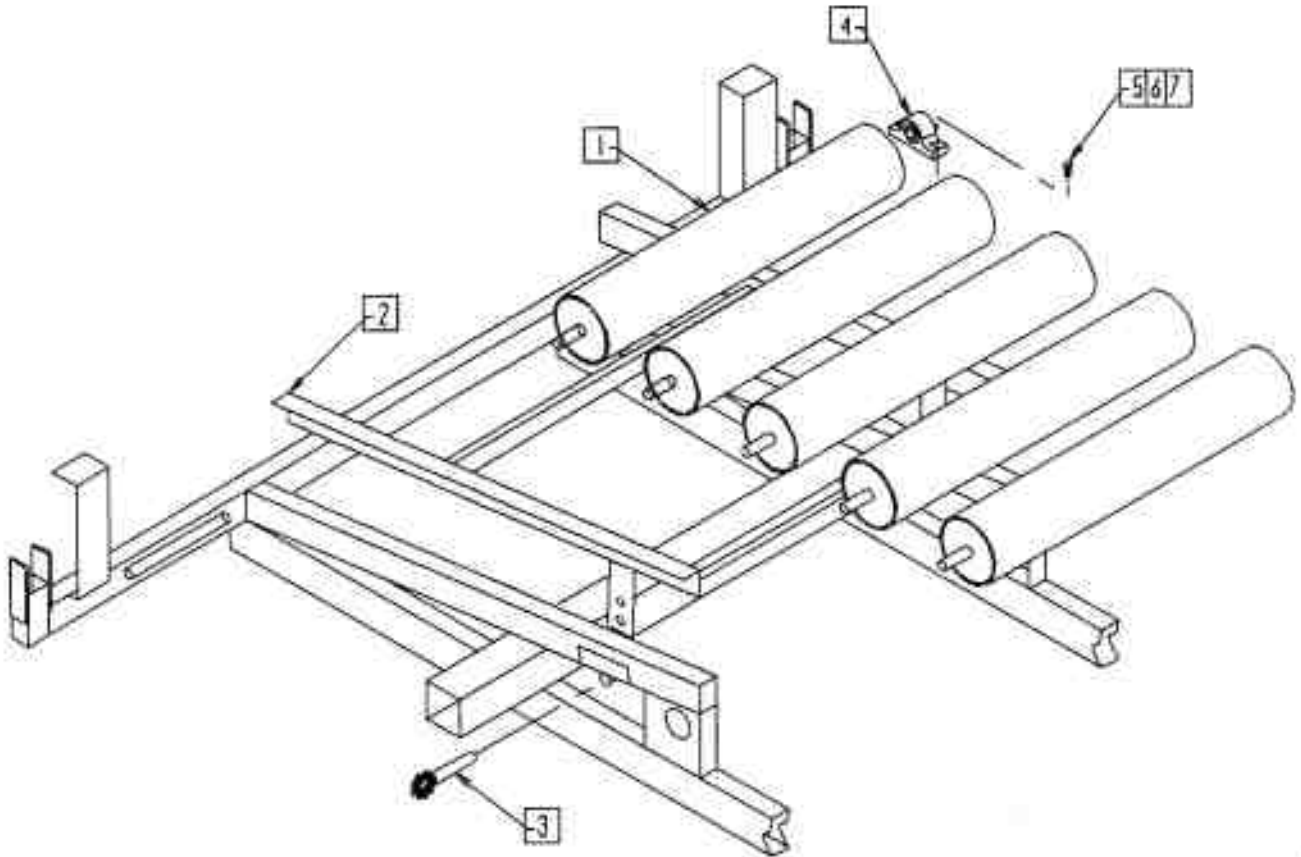

- | | |
|---|------------------------|
| 1 | 5 Large Roller |
| 2 | Riser frame |
| 3 | Riser Lock Pin |
| 4 | 1" Bearing |
| 5 | 20 pc 3/8 x 1 1/2 Bolt |
| 6 | 20 pc 3/8 Lockwasher |
| 7 | 20 pc 3/8 Flatwasher |

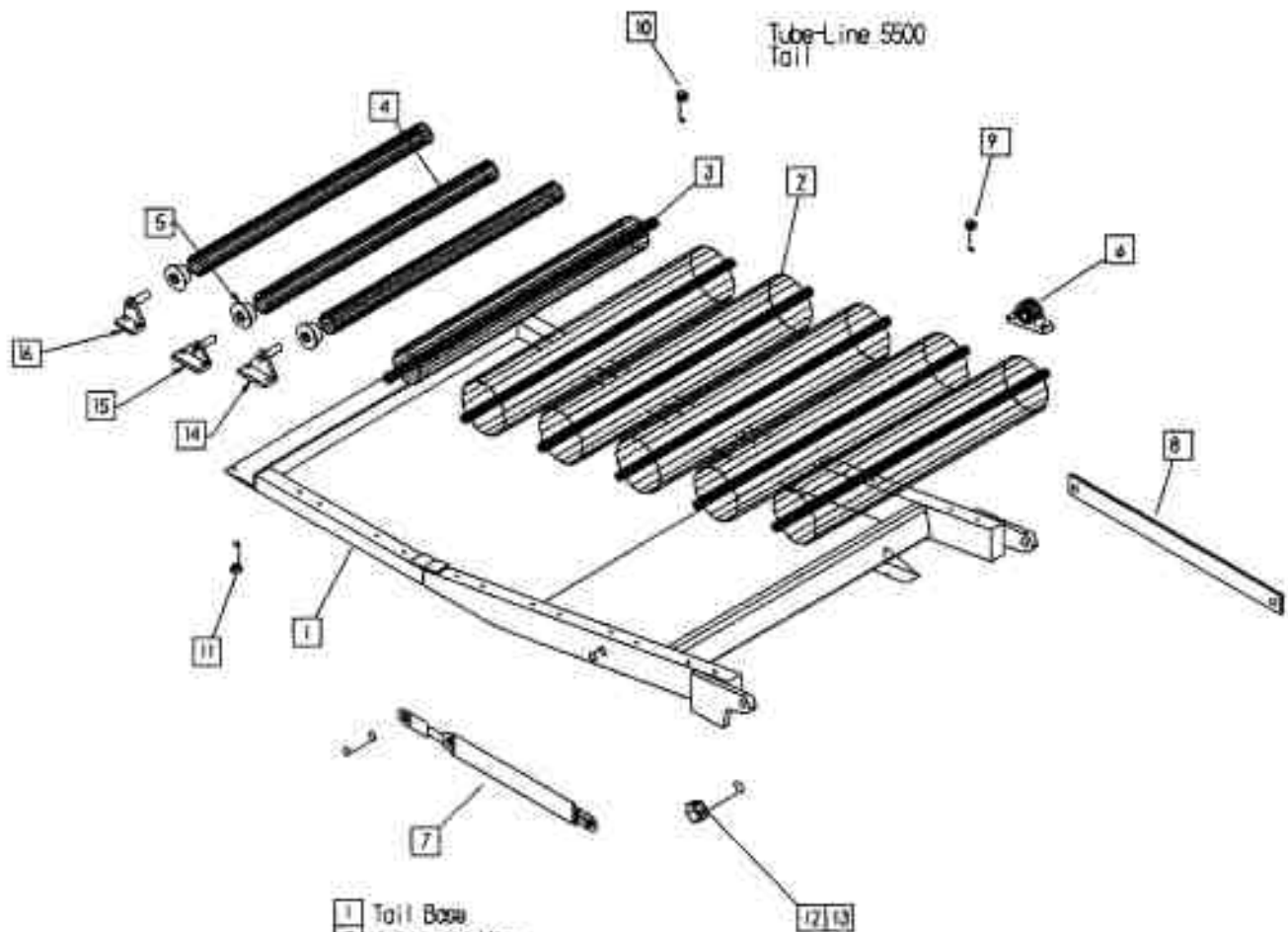

- | | |
|----|----------------------------|
| 1 | Tail Base |
| 2 | 4 large roller |
| 3 | 1 pc 4' roller |
| 4 | 2 pc 2 7/8" roller |
| 5 | 4 pc 3/4" bearing |
| 6 | 10 pc 1" bearing |
| 7 | 3 x 12 hydraulic cylinder |
| 8 | tail tie bar |
| 9 | 3/8 x 1 1/2 bolt |
| 10 | 5/16 x 1 bolt |
| 11 | 4 pc 5/16 x 1 1/2 bolt |
| 12 | 2 pc 1 x 3 1/2 bolt |
| 13 | 2 pc 1" Nylocknut |
| 14 | First Small Roller bracket |
| 15 | 2nd Small Roller Bracket |
| 16 | Last Small Roller bracket |

Tubeline 5500
Bale Saddle

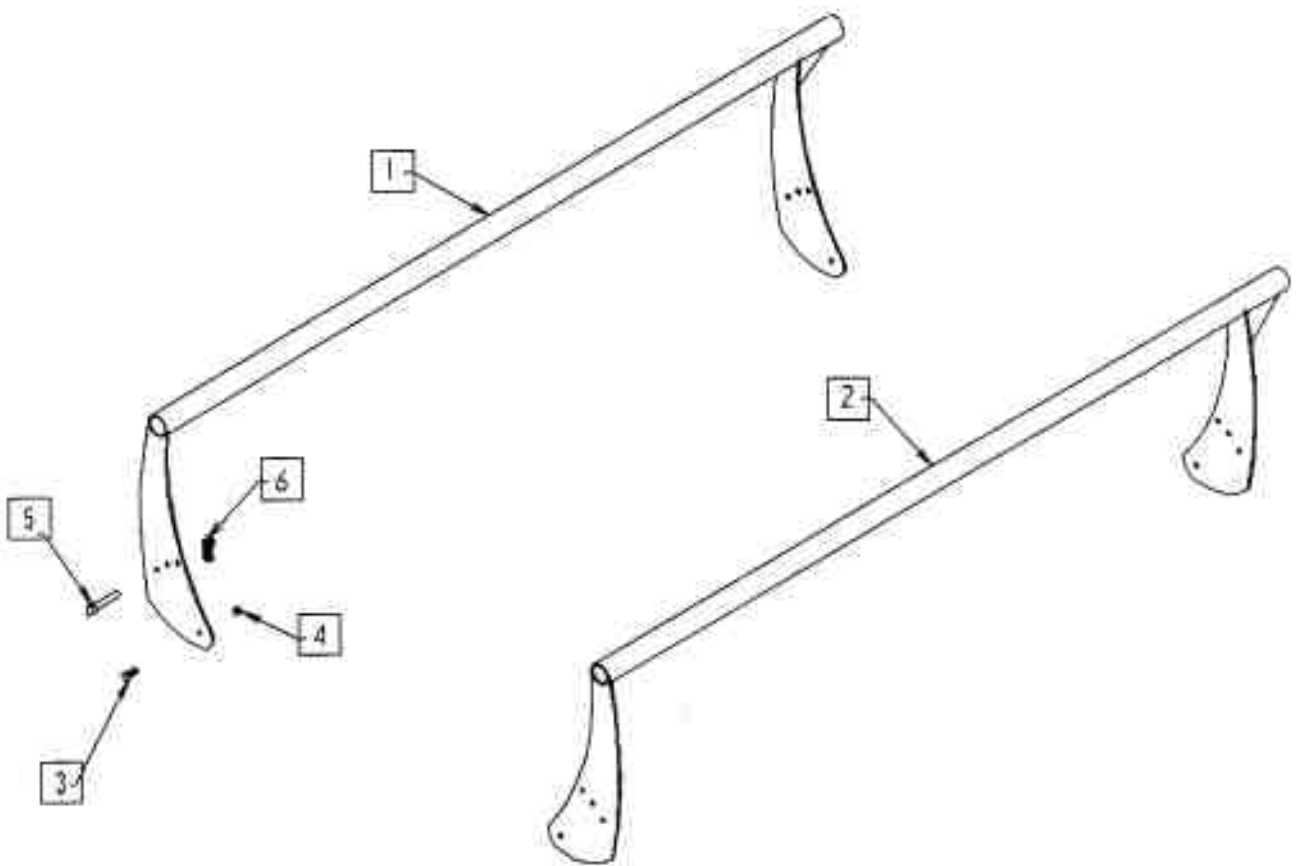

- 1 Bale Saddle (Right Side)
- 2 Bale Saddle (Left Side)
- 3 1/2 x 1 1/4 Bolt
- 4 1/2 Locknut
- 5 1/2 in pin
- 6 3/16 Linch Pin

Tube-Line 5500

Ram

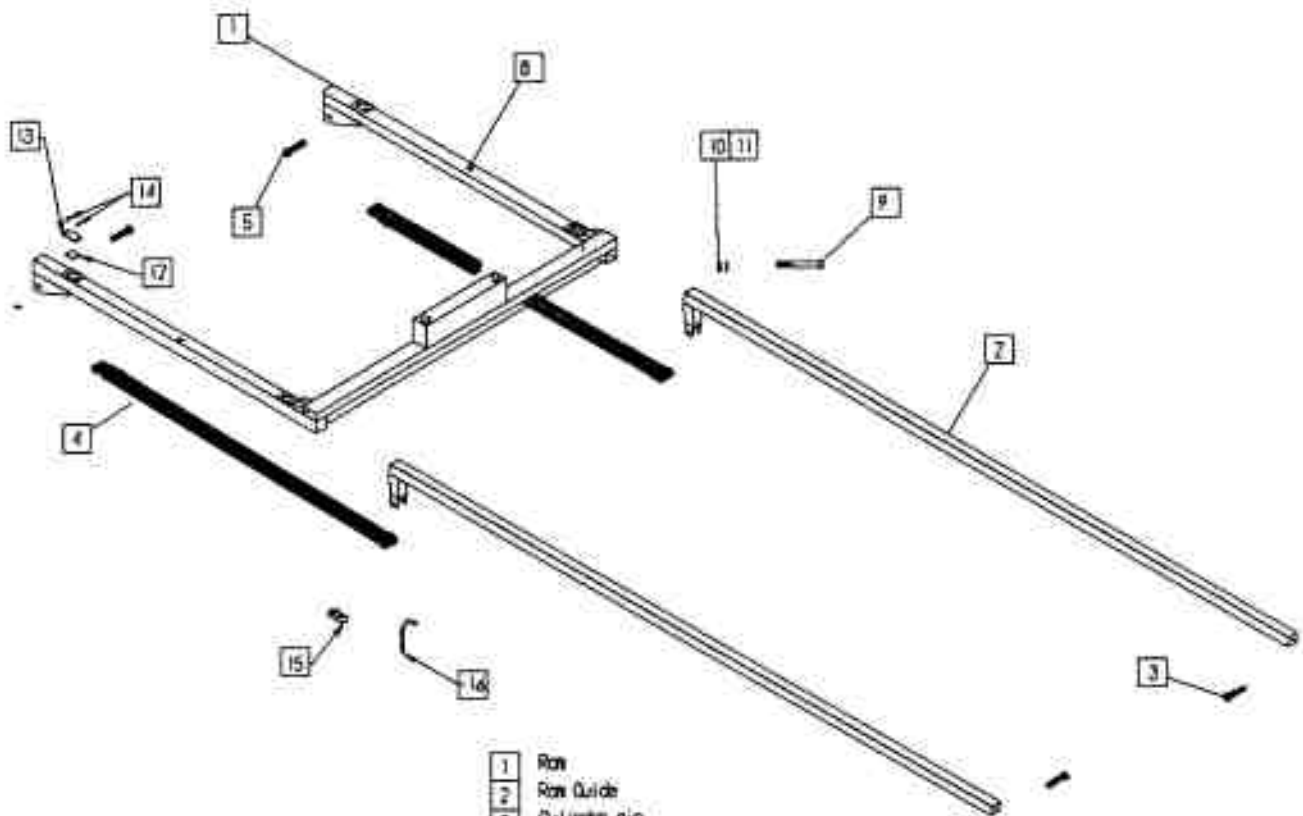

- | | |
|----|-------------------------------|
| 1 | Ram |
| 2 | Ram Guide |
| 3 | Cylinder pin |
| 4 | Roller cylinder |
| 5 | 3/4 x 2 Bolt |
| 6 | 3/4 Lockwasher |
| 7 | 3/4 Flatwasher |
| 8 | 2 pc 1/4 - 28 grease fitting |
| 9 | 2 pc 1/2 X 4 bolt |
| 10 | 2 pc 1/2 nut |
| 11 | 2 pc 1/2 lockwasher |
| 12 | 1/2 x 2 = 2 HDPE slider block |
| 13 | Slider Retainer |
| 14 | 1/4 x 1/2 Hex Socket Bolt |
| 15 | Cylinder support Block |
| 16 | Cylinder Clamp |

Tube - Line 5500
Push - Off

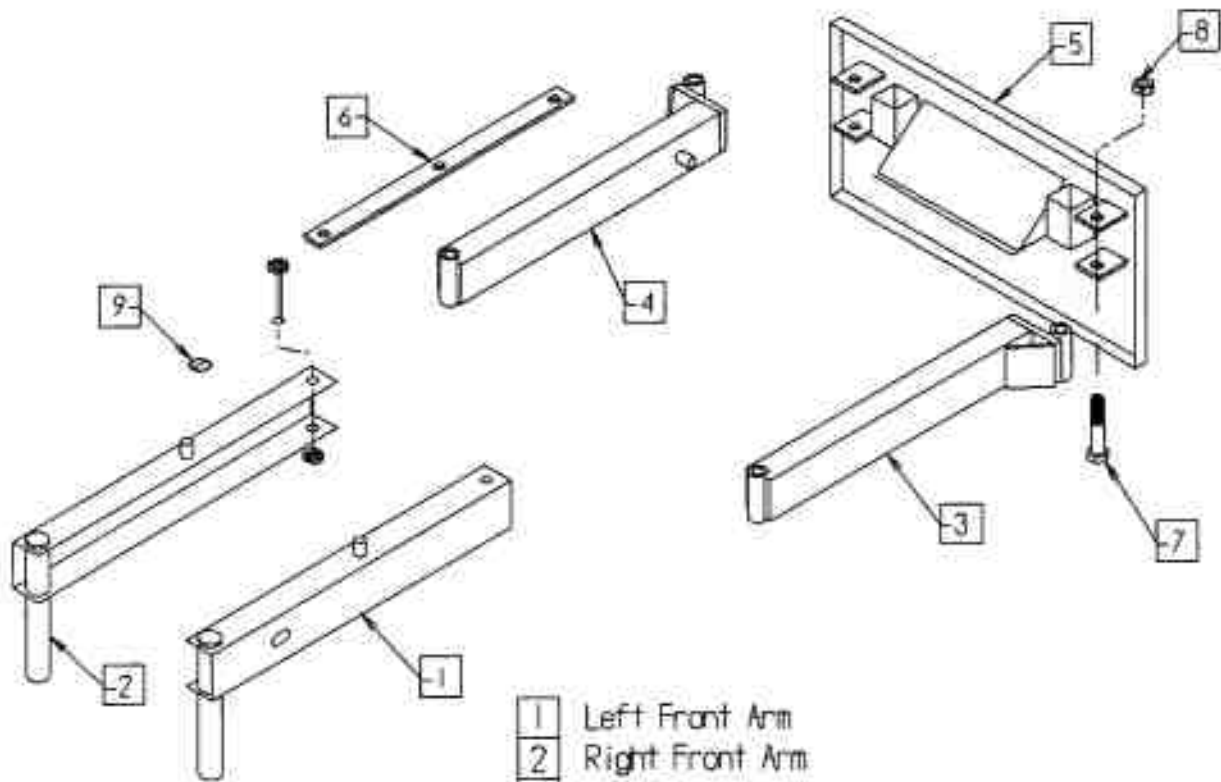

- | | |
|---|---------------------|
| 1 | Left Front Arm |
| 2 | Right Front Arm |
| 3 | Left Rear Arm |
| 4 | Right Rear Arm |
| 5 | Push Plate |
| 6 | 2 pc X Bar |
| 7 | 4 pc 3/4 x 5 Bolt |
| 8 | 4 pc 3/4 Locknut |
| 9 | 4 pc 3/16 Lynch Pin |

4

Tubeline 5500/6500
Push off Channel

